

# USER MANUAL

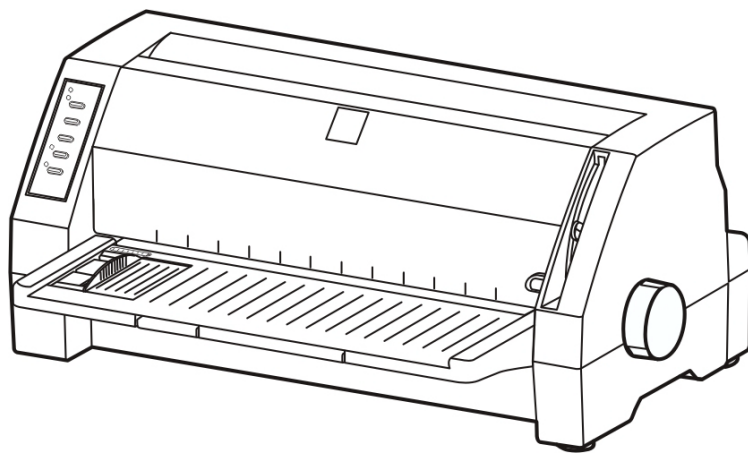

**SEIKO Precision**  
**FB – 390**  
Dot-Matrix Flatbed Printer

# Important Safety Instructions

1. Read all of these instructions carefully and thoroughly and save them for later reference.
2. Follow all warnings and instructions in the manual as well as marked on the product.
3. Unplug this product from the power outlet before cleaning. Do not use liquid or aerosol cleaners. Use a damp cloth for cleaning.
4. Do not use this product near water.
5. Do not place this product on an unstable cart, stand or table. The product may fall, causing serious damage to you or the product.
6. Slots and openings on the cabinet and the back or bottom are provided for air ventilation. To ensure reliable operation of the product and to protect it from overheating, do not block or cover these openings. The openings should never be blocked by placing the product on a bed, sofa, rug or other similar surface. This product should never be placed near or over a radiator or heater. This product should not be placed in a built-in installation or kiosk stand unless proper ventilation is provided.
7. This product should be operated from the type of power source indicated on the rating label. If you are not sure of the type of power available, consult your local dealer or an electrician.
8. Depending on the country of shipment this product may be equipped with a 3-wire grounding-type plug, a plug having a third (grounding) pin. This plug will only fit into a grounding-type power outlet. This is a safety feature. If you are unable to insert the plug into the outlet, contact your local electrician to replace your obsolete outlet. Do not defeat the safety purpose of the grounding-type plug.
9. Do not allow anything to rest on the power cord. Do not locate this product in a location so that the power cord will be walked or driven over or on.
10. Never push objects of any kind into this product through cabinet slots as they may touch dangerous voltage points or short out parts that could result in a risk of fire or electric shock. Never spill liquid of any kind on the product.
11. Except as explained elsewhere in this manual, do not attempt to service this product yourself. Opening and removing those covers that are marked "Do Not Remove" may expose you to dangerous voltage points or other hazardous risks. Leave all servicing on those compartments to qualified service personnel.
12. The mains plug on this equipment must be used to disconnect the mains power.
13. Unplug this product from the power outlet and leave servicing to qualified service personnel under the following conditions:
  - A. When the power cord or plug is damaged or frayed.
  - B. If liquid has been spilled into the product.
  - C. If the product has been exposed to rain or water.
  - D. If the product does not operate normally when the operating instructions are followed. Adjust only those controls that are covered by the operating instructions since importer adjustment of other controls may result in damage and will often require extensive work by a qualified technician to restore the product to normal operation.
  - E. If the product has been dropped or the cabinet has been damaged.
  - F. If the product exhibits a distinct change in performance, indicating a need for service.

Note: The contents of this manual may be changed without prior notice.

# Table of Contents

|   |          |
|---|----------|
| <b>Chapter 1 Overview</b> .....                           | <b>1</b> |
| Features .....  | 1        |
| <b>Chapter 2 Preparation</b> .....                        | <b>3</b> |
| Unpacking .....   | 3        |
| Parts Identification .....                                | 4        |
| Installation .....  | 5        |
| <i>Installing the Front Table Extension Tray</i> .....    | 5        |
| <i>Installing and Replacing the Ribbon Cassette</i> ..... | 5        |
| Connecting the Interface Cable .....                      | 6        |
| Using the Parallel Interface and the USB Interface.....   | 7        |
| Connecting to the Power Source .....                      | 7        |
| <i>Connecting the Power Cord</i> .....                    | 7        |
| <i>Turning the Power on and off</i> .....                 | 7        |
| <b>Chapter 3 Loading paper</b> .....                      | <b>8</b> |
| Paper Thickness Adjustment .....                          | 8        |
| Loading Cut Sheet Paper.....                              | 9        |
| Using Tractor Paper.....                                  | 10       |
| Loading Tractor Paper .....                               | 10       |
| Tearing off Tractor Paper .....                           | 13       |

|   |           |
|---|-----------|
| <b>Chapter 4 Printing from Your Software</b> .....                  | <b>14</b> |
| Setting Up Your Printer To Work With Software .....                 | 14        |
| <b>Chapter 5 Control Panel</b> .....                                | <b>15</b> |
| Control Panel Keys and LEDs .....                                   | 15        |
| Basic Control Panel Operations .....                                | 16        |
| Top of Form Adjustment Mode .....                                   | 16        |
| Tear-off Adjustment Mode .....                                      | 17        |
| Using the Setup Menu System.....                                    | 17        |
| <i>To enter the Setup Menu System and change the settings</i> ..... | 18        |
| <i>To exit the Setup Menu System</i> .....                          | 18        |
| <i>Printing the Current Setting Report</i> .....                    | 19        |
| <i>Options of the Setup Menu System</i> .....                       | 21        |
| Restoring Factory Printer Settings.....                             | 23        |
| Using the Self Test Functions .....                                 | 23        |
| <i>Slide Pattern Printing Test</i> .....                            | 23        |
| <i>Maintenance Printing Test (H pattern)</i> .....                  | 23        |
| Hex Dump Mode .....   | 24        |
| <b>Appendix A</b> .....   | <b>25</b> |
| Maintenance and Fault Finding.....                                  | 25        |
| Error LED on the Control Panel .....                                | 27        |
| <b>Appendix B</b> .....   | <b>28</b> |

|   |    |
|---|----|
| Specifications .....                      | 28 |
| <i>General</i> .....                      | 28 |
| <i>Print Head</i> .....                   | 28 |
| <i>Mechanism</i> .....                    | 29 |
| <i>Paper</i> .....                        | 29 |
| <i>Print mode specifications</i> .....    | 30 |
| <i>Graphic Print Specifications</i> ..... | 31 |
| <i>Parallel Interface</i> .....           | 31 |
| <i>USB Interface</i> .....                | 32 |
| Command Code Summary .....                | 32 |
| <i>Epson Emulation</i> .....              | 32 |
| <i>Select Code Pages</i> .....            | 35 |

# Chapter 1 Overview

## Features

Thank you for purchasing this SEIKO Precision FB-390 printer.

Combining high speed, high quality output with advanced paper handling capabilities, this versatile, 24-pin, flatbed printer is ideal for a wide range of multi-part and cut-sheet printing requirements. Reliability, flexibility and ease-of-use are key features, making the FB-390 the perfect choice for performing demanding applications in a variety of environments.

### **Versatile, Reliable, Straight Paper Path**

---

The straight paper path enables paper to feed through the printer without bending, thus reducing the risk of paper jamming. The versatile FB-390 prints on a wide variety of paper types from 7-part forms to labels, envelopes and reports, as well as media up to 0.45mm thick.

### **Easy Paper Handling**

---

The printer has several other useful features, which help eliminate paper handling problems and ensure quick, accurate results.

#### **Automatic paper loading/ejection with automatic skew detection**

The automatic paper load function ensures cut sheet paper fed into the printer is correctly positioned. The FB-390 also has an automatic skew detection function, which ejects forms which are not fed in straight.

At the touch of a button, tractor paper loaded onto the tractor is automatically set to the printing position. When printing is completed, the paper feeds out to the front table for easy tear-off.

#### **Zero tear-off function**

This causes tractor paper to be automatically fed to the tear-off position at the edge of the window cover, for easy tear-off at the perforations after printing. This zero tear-off capability helps eliminate paper wastage.

#### **Paper park function**

A simple command on the control panel enables the tractor paper to be retracted (parked) outside of the print mechanism so that after switching the paper path select lever, cut sheet paper can be fed into the printer from the front.

After the cut sheet paper has been printed, reverse the paper path lever so that the fanfold stationery can be advanced back into the print mechanism for the next print job.

### **Automatic Interface Switching**

---

The FB-390 is equipped with two interface connectors and therefore accepts both parallel (Centronics) and USB data transfer. The printer automatically detects the type of data transfer received from the host computer and switches to the corresponding interface type.

### **High Resolution Graphics**

---

A maximum resolution of 360×360 DPI enables the printer to produce fine, sharp graphics.

### **User- Friendly Control Panel**

---

Current print status and access to all printer functions is available via simple commands from the control panel. In addition, the control panel is used to access the menu system (Setup Menu System) with complete control over the printer's set-up functions.

### **Emulation**

---

The printer supports the Epson ESC/P2 emulation as standard.

### **Bar Code Generator**

---

NW-7, EAN-13, EAN-8, Code 39, Industrial 2 of 5, Interleaved 2 of 5, Code 128B, and Code 128C are built-in as standard.

# Chapter 2 Preparation

## Unpacking

Check each item against the following packing list, if any of these items are missing, please contact your local dealer.

**NOTE**

**Hold the bottom of printer in the box, then carefully lift it upwards. As you unpack, save all the original packing materials if possible. They are specially designed to protect the printer and will make repacking easy if necessary. Before you start using your new printer, please make sure to remove all the shipping pads from the printer. Open the window cover and remove the shipping pads made from white styrofoam.**

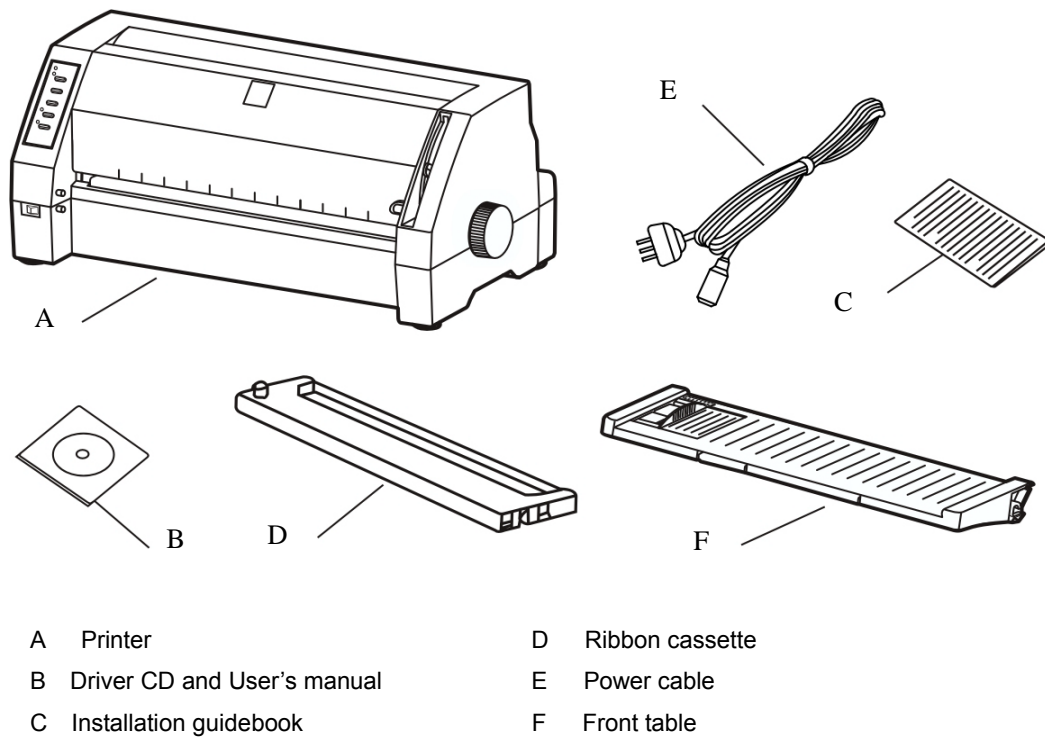

Figure 2-1 Packing list in the printer box



# Parts Identification

Figures 2-2 and 2-3 highlight the main components of the printer.

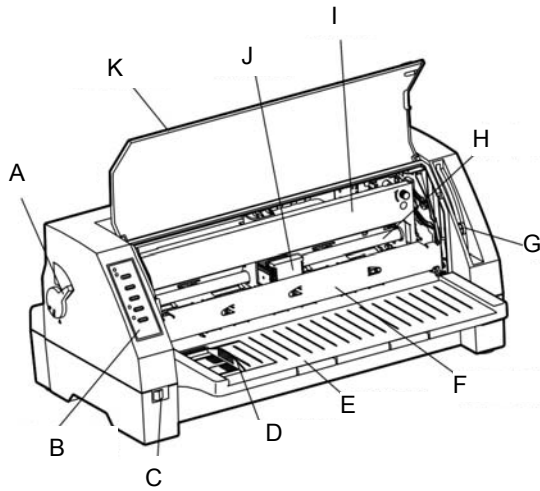

Figure 2-2 Main parts of printer (front view)

- |   |                         |   |                           |
|---|-------------------------|---|---------------------------|
| A | Paper path select lever | G | Gap adjust lever          |
| B | Control panel           | H | Carriage shaft            |
| C | Power switch            | I | Ribbon cassette cartridge |
| D | Cut sheet guide         | J | Print head                |
| E | Front table             | K | Window cover              |
| F | Sub friction roller     |   |                           |

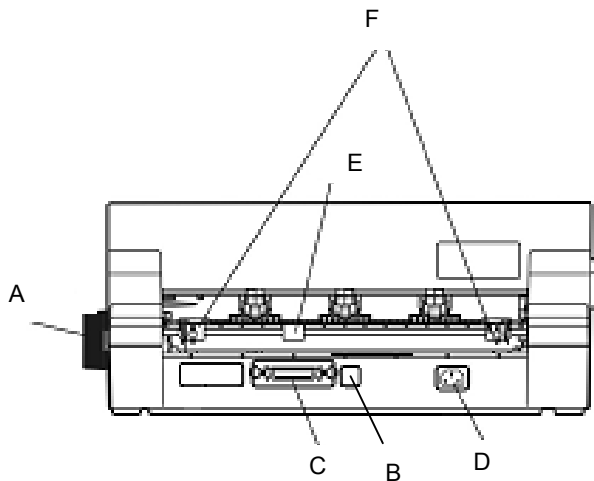

Figure 2-3 Main parts of printer (rear view)

- |   |                              |   |                    |
|---|------------------------------|---|--------------------|
| A | Paper feed knob              | D | Power supply inlet |
| B | USB interface connector      | E | Paper guide pulley |
| C | Parallel interface connector | F | Tractor            |

## Installation

Before placing the printer in your chosen location, consider the following guidelines:

- This printer should be placed on a normal table, printer stand or desk. Be sure that the surface is level, to avoid an uneven load on the carriage as it operates.
- Do not install the printer where it may be subjected to unsuitable conditions such as:
  - Where there is excessive dust.
  - Where it may be splattered with oil or metallic dust.
  - Where it may be exposed to direct sunlight.
  - Where it may be accidentally splashed with water.

## Installing the Front Table Extension Tray

Simply attach it to the front of printer by locating the support lugs in the slots at the edge of the printer front feed.

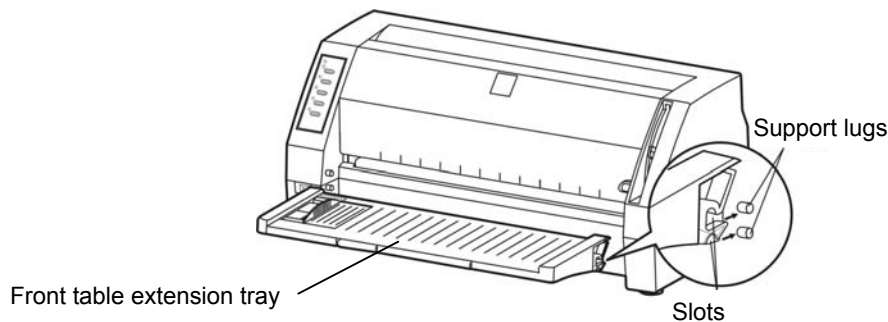

Figure 2-4 Installing the front table extension tray

## Installing and Replacing the Ribbon Cassette

- 1 Make sure the printer is turned OFF and disconnect the power cable.
- 2 Open the printer window cover by holding the side of the window cover as shown in Figure 2-5.

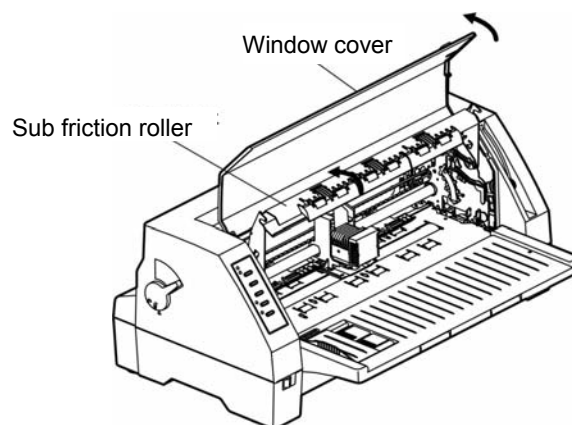

Figure 2-5 Opening the window cover and the Sub friction roller.

- 3 Pull the Sub friction roller by gripping the center area of the unit by your forefingers. Then lift it up until it is positioned upwards towards the top of the printer as shown in Figure 2-5.
- 4 If necessary, move and centre the print head carefully by hand.
- 5 Hold the ribbon cartridge with the knob facing upwards and turn the ribbon knob in the direction shown by the arrow to take up any slack in the ribbon.
- 6 To install the ribbon cartridge, hold it with both hands, with the ribbon facing down as shown if Figure 2-6.

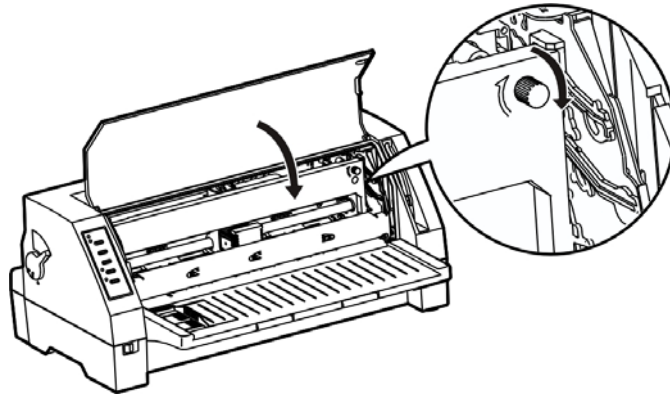

Figure 2-6 Installing the ribbon cassette

**Make sure of the following:**

- When you look at the print head you will find a small piece of black plastic on the thin metal sheet of the ribbon guide. Make sure that the ribbon goes under the piece of plastic.
  - Position the ribbon cartridge with the tabs on its case over the slots inside the printer case.
  - With the ribbon cartridge and ribbon correctly positioned, gently push the cartridge towards the back of printer until it clicks into place.
- 7 Move the print head from side a few times to make sure the ribbon slides into the ribbon guides.
  - 8 Having installed the ribbon, lower the sub friction roller and gently push it shut until you hear a click. Then close the window cover.

## **Connecting the Interface Cable**

Connect the parallel or USB interface cable as shown in figure 2-7 on the next page:

**Caution**

Make sure that the power switches of both printer and host computer are turned OFF before you connect the parallel interface cable.

## Using the Parallel Interface and the USB Interface

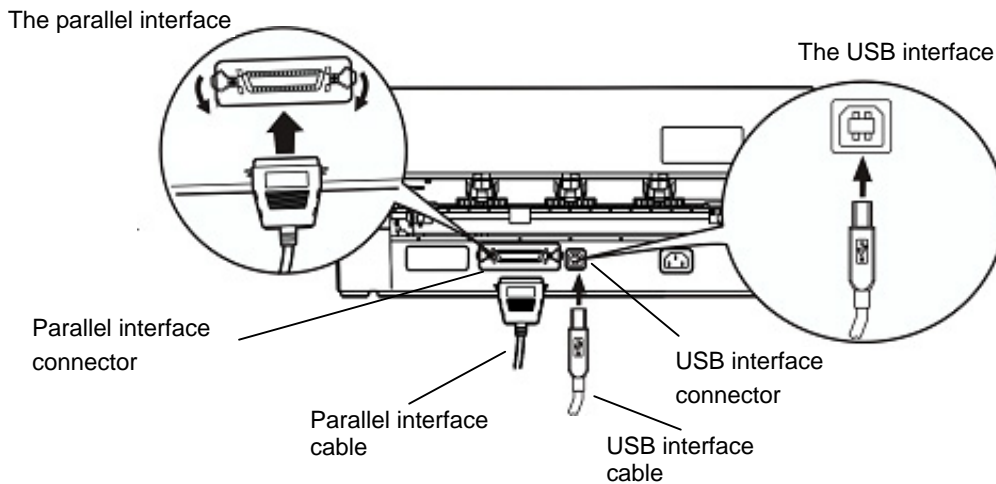

Figure 2-7 Connecting the parallel interface cable and the USB interface cable

## Connecting to the Power Source

### Connecting the Power Cord

Plug the power cord (supplied) into the power inlet at the rear of the printer.

Check that the power switch (located on the front of the printer) is in the OFF position, and then plug the power cord into the wall outlet.

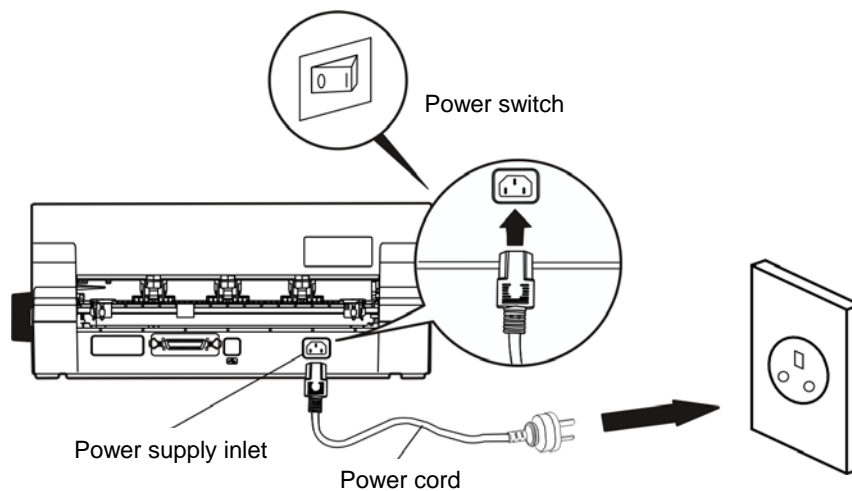

Figure 2-8 Connecting the power cord to the printer

## Turning the Power on and off

To turn the printer ON, press the **I** mark at the side of the power switch.

To turn the printer OFF, press the **O** mark at the side of the power switch.

# Chapter 3 Loading paper

## Paper Thickness Adjustment

Before loading cut sheet or tractor paper, you have to adjust the gap adjust lever on the front right side of the printer.

To feed thicker papers through the printer, you need to move the gap adjust lever from its standard position.

The lever moves the print head relative to the platen so that there is more room for the paper.

### Adjusting the gap adjust lever

To obtain good quality printing and prevent problems (paper jam etc.), adjust the gap adjust lever as shown in the Figure 3-1. The scale number # 1 shown in Figure 3-1 identifies the standard paper thickness setting. This is the recommended setting for most papers. Use Table 3-1 to find the recommended setting for other papers.

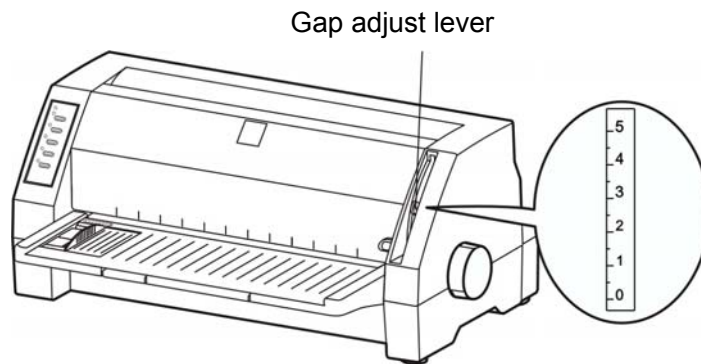

Figure 3-1 Setting the gap adjust lever

| Position | Copies | Thickness      |
|----------|--------|----------------|
| 5        | 7      | 0.45mm         |
| 4        | 6      | 0.36mm         |
| 3        | 4 or 5 | 0.24 to 0.30mm |
| 2        | 2 or 3 | 0.12 to 0.18mm |
| 1        | 1      | 0.06mm         |

Table 3-1 Paper thickness setting

## Loading Cut Sheet Paper

- 1 Turn the printer on.
- 2 Set paper select lever toward the back of printer as shown in Figure 3-2.

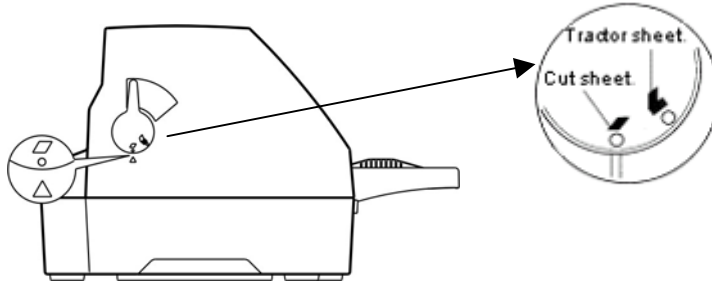

Figure 3-2 Setting the paper select lever

- 3 Set the gap adjust lever for example to the position "1" for thin paper.
- 4 Position the left cut sheet guide by referring to the marking on the window cover. The positions for A4 and Letter size paper are indicated on the left side of the window cover as shown in Figure 3-3.

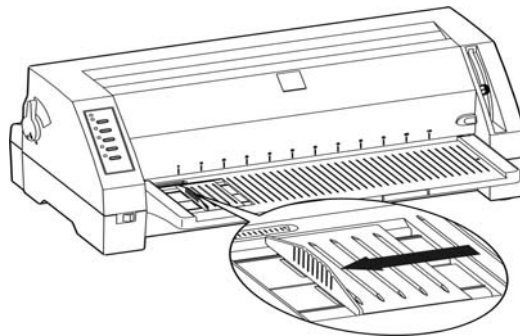

Figure 3-3 Adjusting the paper guide

- 5 Please pull out the small Front table extension tabs if the size of paper is long and requires extra support, as shown in Figure 3-4

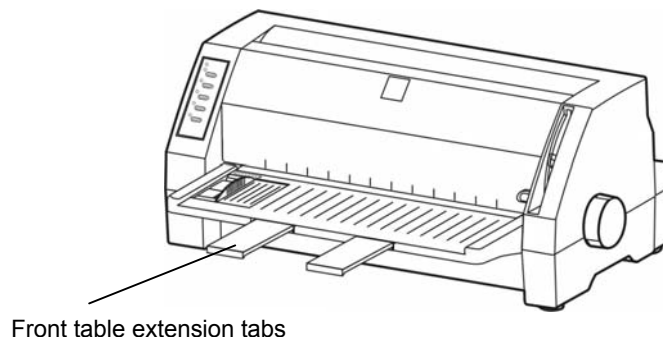

Figure 3-4 Pull out the small front table extension tabs

- 6 Insert the paper as shown in Figure 3 - 5. The paper is fed into the printer automatically and stops at the print start

position. You can set the printer to detect skew so if the paper skews during loading, the printer detects it and automatically ejects the paper to the front table.

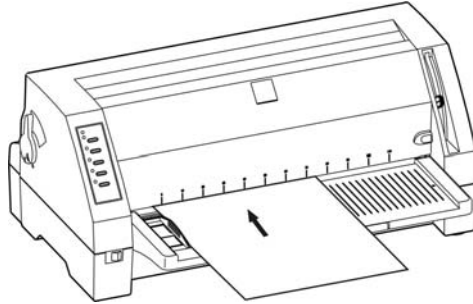

Figure 3-5 Loading cut sheet

7 After the above steps, the printer is ready to print.

#### **NOTE**

The printer's skew detection level can be set within the Setup Menu System. Be careful with the lowest possible setting because the printer might reject the paper due to even the smallest skew. If this happens, try a more medium setting.

## **Using Tractor Paper**

This printer feeds tractor paper from the rear of the printer to the front.

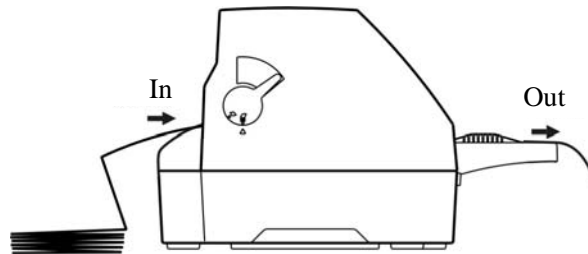

Figure 3-6 Feeding direction of tractor paper

## **Loading Tractor Paper**

- 1 Turn the printer on.
- 2 Set paper select lever toward the front of printer as shown in Figure 3-7.

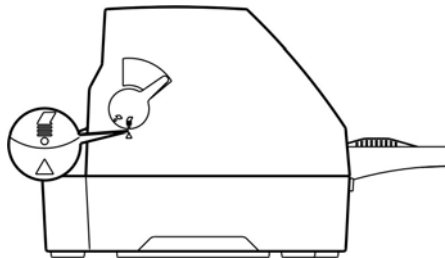

Figure 3-7 Setting the paper select lever

- 3 Move the left cut sheet guide to the far left as much as possible.

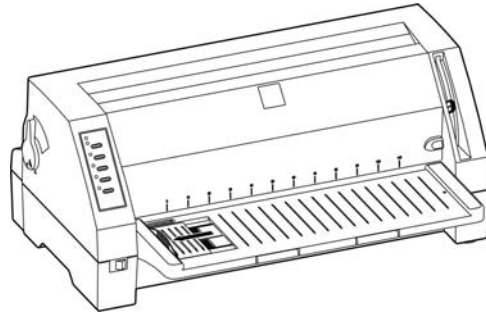

Figure 3-8 Moving the left cut sheet guide to the far left

- 4 Release the lock lever of tractor.

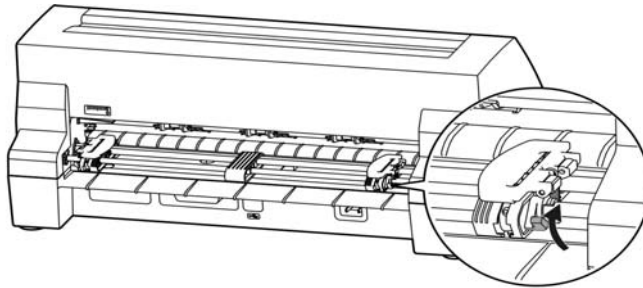

Figure 3-9 Releasing the lock lever of the right tractor (view from rear)

- 5 Move the left tractor to the left proper position (The “0” position indicates the horizontal starting print position). When moving the left tractor to the leftmost position, the distance between the starting print position and the centre of the sprocket pins is 11.75cm. Lock the left tractor. Moving the right tractor to the proper position, but do not lock it yet.

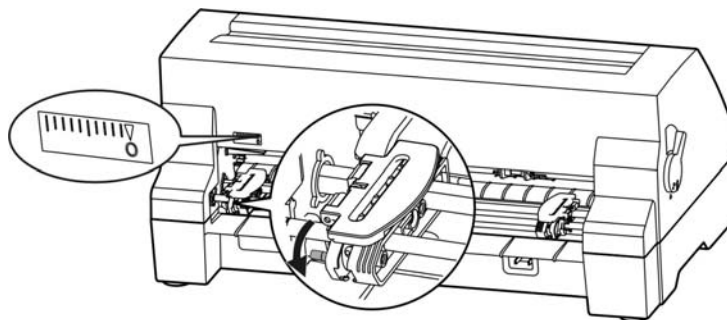

Figure 3-10 Adjusting the tractor position

- 6 Move the paper guide pulleys to the center between the left and right tractor.



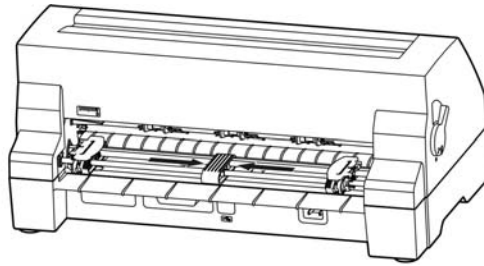

Figure 3-11 Adjusting the paper guide pulley position

- 7 Open the tractor covers and place the paper on the sprocket pins. If you are using preprinted paper or labels, install them with the printed or labeled side facing upwards.

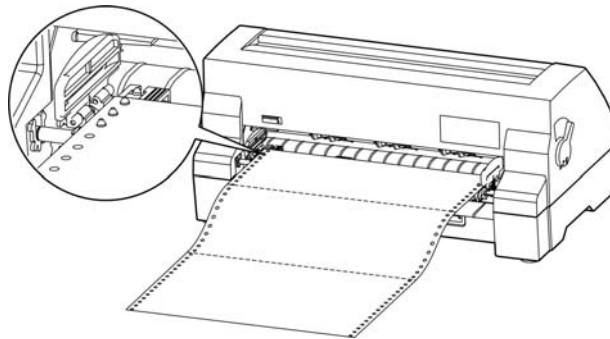

Figure 3-12 Setting paper on the sprocket pins

- 8 Close the tractor covers.

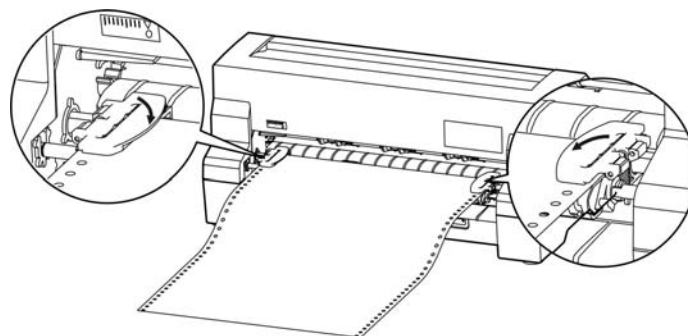

Figure 3-13 Close the tractor covers.

- 9 Slide the right tractor to the left to take up any slack in the paper, and then fasten the lock lever to fix the tractor in position. Ensure the tractor paper is in line with the print start position. If the paper is not aligned with the print start position, align the paper, and then fasten the lock lever to lock the tractors.

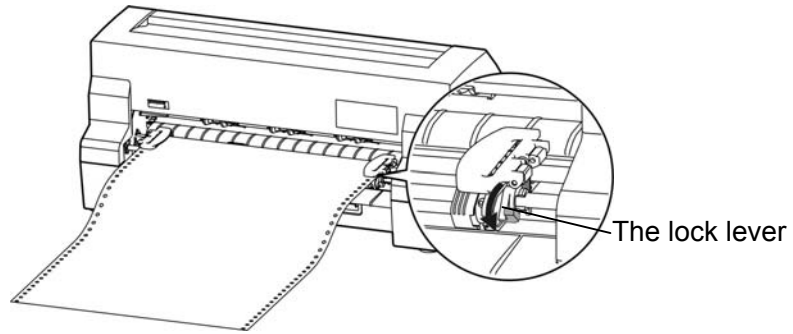

Figure 3-14 Locking the position of the right tractor

- 10 When starting a new print task, the printer will automatically load the paper before the actual printing starts. (You can also press the **PARK/LOAD** key to load the paper manually.)

## Tearing off Tractor Paper

To tear off the paper, make sure that printed-paper is fed to the front table. If not, switch the printer offline then press the **PARK/LOAD** key.

Hold the edge of the paper and pull it towards the edge of the window cover as shown in Figure 3-15. If the perforation of the paper is not at the edge of the window cover, adjust the tear-off position (refer to chapter 5, Control Panel)

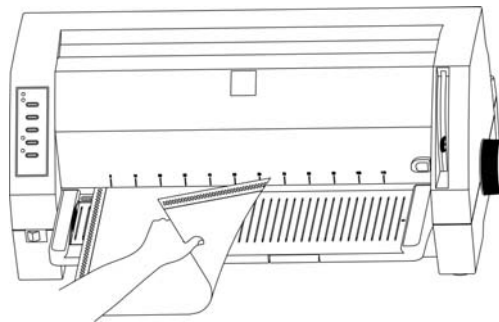

Figure 3-15 Tractor paper tear-off

# Chapter 4 Printing from Your Software

## Setting Up Your Printer To Work With Software

- The printer supports the Epson ESC/P2 emulation.

You can select the Epson LQ-570+ driver for this printer, but the best way to ensure that all the features of your printer are supported by the software is to use the SEIKO Precision printer driver. If the driver is not available in your software package please call your software company. You may also check our web site for the suitable driver since we are updating the available drivers from time to time.

Your printer is supplied with a CD-Rom including the printer drivers for Microsoft Windows 98 and Windows 2000/XP. Please load the printer driver into your software according to the instructions on the driver CD.

# Chapter 5 Control Panel

## Control Panel Keys and LEDs

The control panel consists of five keys and four LEDs as shown in Figure 5-1

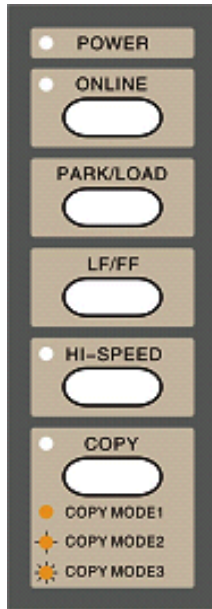

Figure 5-1 The printer control panel

The following table details each indicator LED function:

| Indicator LED                | On  | Off  |
|------------------------------|---|--|
| <b>POWER</b><br>(green)      | Lights when the printer is turned on. It flashes when paper runs out and during error condition (See Appendix A)                                  | The printer is turned off.                 |
| <b>ONLINE</b><br>(green)     | Lights when the printer is online.  | The printer is offline                     |
| <b>HI-SPEED</b><br>(green)   | Lights when the printer is in high speed mode. Flashes in super high speed mode.  | The printer is in the letter quality mode. |
| <b>COPY MODE</b><br>(yellow) | Lights when the printer is in COPY MODE 1. Flashes slowly when the printer is in COPY MODE 2. Flashes quickly when the printer is in COPY MODE 3. | The printer is in the normal mode.         |

Table 5-1 LEDs on the control panel

### NOTE

If you set the scale number of the lever position equal to or greater than 2 in the normal mode, the printer will transfer to the COPY MODE 1 as the current printing mode. However, the COPY MODE LED is still off.

## Basic Control Panel Operations

You can use the five keys on the control panel to operate your printer.

- ONLINE** Pressing the **ONLINE** button, toggles between **ONLINE** and **OFFLINE** mode.
- PARK/LOAD** In the offline mode, pressing the **PARK/LOAD** button shortly controls feeding tractor paper or cut sheets
- LF/FF** In the offline mode, press the **LF/FF** key to feed the paper line by line. Alternatively, hold the key down for 2 seconds, the printer will eject the single sheet paper, or advance the tractor paper to the tear-off position. And if you press LF/FF key again the tractor paper will be reversely fed to the top-of-form position of the next page.
- COPY** In the offline mode, pressing the **COPY** key toggles among the four modes: **NORMAL**, **COPY MODE 1**, **COPY MODE 2** and **COPY MODE 3**.
- HI-SPEED** In the offline mode, pressing the **HI-SPEED** key, toggles among the **HI-SPEED** mode, **SUPER HIGH-SPEED** mode and **LETTER QUALITY** mode.

### NOTE

1. The printer can only print **DRAFT** font in the **HIGH-SPEED** or **SUPER HIGH-SPEED** mode. If you need any other font listed in the **SETUP MENU SYSTEM**, please change to the **LETTER QUALITY** mode.
2. **SUPER HIGH-SPEED** mode will be invalid when printing graphic images.
3. Push button selections may override the menu selections.

## Top of Form Adjustment Mode

The top of form setting determines the margin between the top of paper and the first printed line (the top margin).

In the **ONLINE** mode, press the **LF/FF** key for about 3 seconds to enter the top of form adjustment mode. The **ONLINE** and **POWER LED** will blink alternating.

### NOTE

Your application software usually sets your top margin. You shouldn't need to change the top-of-form setting very often.

Use the **PARK/LOAD** and **LF/FF** keys to alter the top of form setting:

**PARK/LOAD:** Increase the top of form by 1/60 inch. You can increase the margin to a maximum of +60 increments (+60/60 inch) from the factory setting.

**LF/FF:** Decrease the top of form by 1/60 inch. You can decrease the margin to a maximum of -10 (-10/60 inch) from the default setting.

Press the **ONLINE** key to exit and save your new setting. The **POWER LED** and **ONLINE LED** blink simultaneously 3 times with a beep, and then the **POWER LED** will be on.

**NOTE**

**To exit without saving, just turn the printer OFF.**

## Tear-off Adjustment Mode

There is a tear-off bar at the edge of the window cover. When you have finished printing, you can advance the tractor paper on the tracker to the tear-off bar by the tear-off function to easily tear off the perforated sheets. The tear-off setting determines the distance between the perforation of tractor paper and the tear-off bar. If the default distance is not suitable for you, you can adjust it by the printer's tear-off adjustment feature.

With the printer online, press both the **PARK/LOAD** and **LF/FF** keys for about 3 seconds to get the printer to enter the tear-off adjustment mode. When the printer enters this mode, the **ONLINE LED** and the **POWER LED** blink alternately.

Use the **PARK/LOAD** and **LF/FF** keys to alter the tear-off setting:

**PARK/LOAD:** Press the **PARK/LOAD** key to adjust the distance in 1/60 inch increments. You can maximum increase to +15/60 inch

**LF/FF:** Press the **LF/FF** key to adjust the distance in 1/60 inch decrements. You can maximum decrease to -15/60 inch

To exit and save your new setting, press **ONLINE** key. The **POWER LED** and the **ONLINE LED** blink simultaneously for 3 times, then the **POWER LED** turns on. Your new tear-off setting value is saved.

**NOTE**

**To exit without saving, just turn off the printer.**

## Using the Setup Menu System

The factory settings of this printer are selected to meet the requirements of the majority of users. However, you may want to use a different character set for a different language or you may prefer printing in different font or style. To achieve this, you can use the Setup Menu System to create your own printer settings by modifying or changing the factory defaults.

The Setup Menu System is divided into several groups, and each group contains a number of

menu lists, each list containing several settings. You can select a new setting of the menu list and save it, or just go to the next menu list without altering the current setting.

## To enter the Setup Menu System and change the settings

1. Lift the window cover of the printer.
2. Eject any paper currently in the printer (or park tractor paper) then switch the printer **ONLINE**.
3. Keep pressing the **PARK/LOAD** key for 3 seconds.

*This starts the Setup Menu System and prints the instructions for using it. The current setting is underlined.*

*The print head points to the current selection in the menu.*

4. Make a selection from the menu with the keys on the control panel:

| <b>Press:</b>    | <b>To:</b>   |
|------------------|--|
| <b>PARK/LOAD</b> | Move the print head to the next menu selection. Repeat this until you get the selection that you want. |
| <b>LF/FF</b>     | Save the setting that is currently indicated by the print head position, and go to the next menu.      |
| <b>ONLINE</b>    | Move to the next menu without altering the current setting.  |
| <b>COPY</b>      | Go to the next menu group.   |

5. When you have made all of your settings (remember that you don't have to go all the way through the menu system), switch the printer off and then turn on again.

Each time you switch the printer on it uses the new saved settings. Keep the printout of the menu selections so that you know what the current settings are.

## To exit the Setup Menu System

Turn the printer off, and then turn on again.

\* New settings of the menu will be stored.

### **NOTE**

1. **You do not have to go all the way through the menu system. Once you have made all the changes you want, you only need to exit the Setup Menu System by switching off the printer. When you switch it on again, the printer will read and use the new settings.**
2. **When the compressed mode is effective, the High Speed mode and Super High Speed mode will not be valid.**

## Printing the Current Setting Report

You can use the information in the current setting report to decide which setting you want to change.

### To print the current settings:

1. Turn the printer off.
2. Hold down both the **PARK/LOAD** and **LF/FF** key at the same time
3. Turn the printer on.

The printer automatically loads paper and prints the current settings. An example print out is shown in Figure 5-2.



**SEIKO Precision FB-390**  
Current Setting Report

Current settings are **FILLED**.

**PRINT STYLE**

|       |               |          |         |              |        |       |       |
|-------|---------------|----------|---------|--------------|--------|-------|-------|
| FONT  | <u>ROMAN</u>  | SANS SER | COURIER | PRESTIGE     | SCRIPT | OCR-B | OCR-A |
| PITCH | <u>10 CPI</u> | 12 CPI   | 15 CPI  | PROPORTIONAL |        |       |       |

**PAGE LAYOUT**

|              |               |        |        |           |         |         |
|--------------|---------------|--------|--------|-----------|---------|---------|
| LINE SPACING | <u>6 LPI</u>  | 8 LPI  |        |           |         |         |
| FORM LENGTH  | <u>5 INCH</u> | 7 INCH | LETTER | <u>A4</u> | 12 INCH | 14 INCH |
| PAGE SKIP    | <u>OFF</u>    | ON     |        |           |         |         |
| COMPRESS PRT | <u>NORMAL</u> | 75%    |        |           |         |         |

**PRINT MODE**

|             |               |                |
|-------------|---------------|----------------|
| TEXT DIR    | <u>BI-DIR</u> | UNI-DIR        |
| GRAPHIC DIR | BI-DIR        | <u>UNI-DIR</u> |

**CHARACTER**

|               |               |                 |           |           |          |           |          |
|---------------|---------------|-----------------|-----------|-----------|----------|-----------|----------|
| SLASH ZERO    | <u>OFF</u>    | ON              |           |           |          |           |          |
| CHARACTER SET | ITALICS       | <u>GRAPHICS</u> |           |           |          |           |          |
| INTL CHAR SET | <u>U.S.A.</u> | FRANCE          | GERMANY   | U.K.      | DENMARK1 | SWEDEN    | ITALY    |
|               | SPAIN 1       | JAPAN           | NORWAY    | DENMARK2  | SPAN 2   | LATIN AM  | KOREA    |
|               | LEGAL         |                 |           |           |          |           |          |
| CODE PAGE     | <u>U.S.A.</u> | MULTI           | PORTUGAL  | CANADA    | NORWAY   | EAST EURO | CYRILLIC |
|               | RUSSIAN       | HUNGARY         | KAMENICKY | TURKEY    | ICELAND  | BULGARIA  | MAZOVIA  |
|               | GRK 437       | GRK 851         | GRK8859-7 | GRK 1253  | ARAB NLS | ARAB EXT  | WIN LATI |
|               | WIN LAT2      | ISO LTN1        | ISO LTN2  | TUR8859-9 | ISO LTN9 | KBL       | LATIN 7  |

**INSTALL**

|                |            |          |                 |          |     |     |     |
|----------------|------------|----------|-----------------|----------|-----|-----|-----|
| QUIET MODE     | <u>OFF</u> | ON       |                 |          |     |     |     |
| AUTO LF        | <u>OFF</u> | ON       |                 |          |     |     |     |
| AUTO TEAR OFF  | OFF        | 0.3 SEC. | <u>0.5 SEC.</u> | 1.0 SEC. |     |     |     |
| LOADING        | PUSH KEY   | 0.5 SEC. | <u>1.0 SEC.</u> | 2.0 SEC. |     |     |     |
| SKEW DETECTION | <u>OFF</u> | ON       |                 |          |     |     |     |
| SKEW LEVEL     | 001        | 002      | <u>003</u>      | 004      | 005 | 006 | 007 |
|                | 008        | 009      | 010             |          |     |     |     |

Figure 5-2 Current Setting Report

## Options of the Setup Menu System

The following printout in Figure 5-3 shows the selections from the Setup Menu System and is followed by a description of how to use it in Table 5-2 (Options of the Setup Menu System).

| <b>SEIKO Precision FB-390</b>   |               |                 |                 |              |          |           |          |
|---|---------------|-----------------|-----------------|--------------|----------|-----------|----------|
| SETUP MENU SYSTEM   |               |                 |                 |              |          |           |          |
| Use the PARK/LOAD key to point the print head to the desired setting.         |               |                 |                 |              |          |           |          |
| Use the LF/FF key to store the new setting and go to the next menu.           |               |                 |                 |              |          |           |          |
| Use the ONLINE key to go to the next menu without storing a new setting.      |               |                 |                 |              |          |           |          |
| Use the COPY key to go to the next menu group.                                |               |                 |                 |              |          |           |          |
| Current settings are <u>UNDERLINED</u> . New settings will be <b>FILLED</b> . |               |                 |                 |              |          |           |          |
| <b>PRINT STYLE</b>  |               |                 |                 |              |          |           |          |
| FONT  | <u>ROMAN</u>  | SANS SER        | COURIER         | PRESTIGE     | SCRIPT   | OCR-B     | OCR-A    |
| PITCH   | <u>10 CPI</u> | 12 CPI          | 15 CPI          | PROPORTIONAL |          |           |          |
| <b>PAGE LAYOUT</b>  |               |                 |                 |              |          |           |          |
| LINE SPACING  | <u>6 LPI</u>  | 8 LPI           |                 |              |          |           |          |
| FORM LENGTH   | <u>5 INCH</u> | 7 INCH          | LETTER          | <u>A4</u>    | 12 INCH  | 14 INCH   |          |
| PAGE SKIP   | <u>OFF</u>    | ON              |                 |              |          |           |          |
| COMPRESS PRT  | <u>NORMAL</u> | 75%             |                 |              |          |           |          |
| <b>PRINT MODE</b>   |               |                 |                 |              |          |           |          |
| TEXT DIR  | <u>BI-DIR</u> | UNI-DIR         |                 |              |          |           |          |
| GRAPHIC DIR   | <u>BI-DIR</u> | UNI-DIR         |                 |              |          |           |          |
| <b>CHARACTER</b>  |               |                 |                 |              |          |           |          |
| SLASH ZERO  | <u>OFF</u>    | ON              |                 |              |          |           |          |
| CHARACTER SET   | ITALICS       | <u>GRAPHICS</u> |                 |              |          |           |          |
| INTL CHAR SET   | <u>U.S.A.</u> | FRANCE          | GERMANY         | U.K.         | DENMARK1 | SWEDEN    | ITALY    |
|   | SPAIN 1       | JAPAN           | NORWAY          | DENMARK2     | SPAN 2   | LATIN AM  | KOREA    |
|   | LEGAL         |                 |                 |              |          |           |          |
| CODE PAGE   | <u>U.S.A.</u> | MULTI           | PORTUGAL        | CANADA       | NORWAY   | EAST EURO | CYRILLIC |
|   | RUSSIAN       | HUNGARY         | KAMENICKY       | TURKEY       | ICELAND  | BULGARIA  | MAZOVIA  |
|   | GRK 437       | GRK 851         | GRK8859-7       | GRK 1253     | ARAB NLS | ARAB EXT  | WIN LATI |
|   | WIN LAT2      | ISO LTN1        | ISO LTN2        | TUR8859-9    | ISO LTN9 | KBL       | LATIN 7  |
| <b>INSTALL</b>  |               |                 |                 |              |          |           |          |
| QUIET MODE  | <u>OFF</u>    | ON              |                 |              |          |           |          |
| AUTO LF   | <u>OFF</u>    | ON              |                 |              |          |           |          |
| AUTO TEAR OFF   | OFF           | 0.3 SEC.        | <u>0.5 SEC.</u> | 1.0 SEC.     |          |           |          |
| LOADING   | PUSH KEY      | 0.5 SEC.        | <u>1.0 SEC.</u> | 2.0 SEC.     |          |           |          |
| SKEW DETECTION  | <u>OFF</u>    | ON              |                 |              |          |           |          |
| SKEW LEVEL  | 001           | 002             | <u>003</u>      | 004          | 005      | 006       | 007      |
|   | 008           | 009             | 010             |              |          |           |          |
| To activate the newly stored settings, please turn on the power again.        |               |                 |                 |              |          |           |          |

Figure 5-3 Setup Menu System

| <b>Options</b> | <b>Description</b>  |
|----------------|---|
| FONT           | Set the font for the printer to use in the absence of any font control instructions from your software.   |
| PITCH          | Set the pitch to determine the horizontal spacing of the printed characters.  |
| LINE SPACING   | Set the vertical spacing of the printed characters. You can set it to either 6 LPI (the default setting) or 8 LPI.  |
| FORM LENGTH    | Set the length of your printer paper, for both cut sheets and continuous-feed paper.  |
| PAGE SKIP      | Select (ON) or cancel (OFF, the default) a bottom margin of one inch.   |
| COMPRESS PRT   | Select compressed print mode or normal print mode.  |
| TEXT DIR       | Set unidirectional or bi-directional printing for text. Bi-directional (the default) is faster because the print head prints in both directions. Unidirectional is slower but produces better printing quality.   |
| GRAPHIC DIR    | Set unidirectional or bi-directional printing for graphics. It is set to UNI-DIR by default for better quality.   |
| SLASH ZERO     | Select or cancel the printing of a slash (/) through zero to distinguish them from the letter O.  |
| CHARACTER SET  | Select character set into Italic Character Table or Graphic Character Table.  |
| INTL CHAR SET  | Select among international character sets.  |
| CODE PAGE      | Select a code page  |
| QUIET MODE     | Select the printer into quiet mode. The acoustic noise is lower but the printing speed is reduced by half.  |
| AUTO LF        | Select (ON) or cancel (OFF) the automatic advance of the paper by one line after every carriage return command.   |
| AUTO TEAR OFF  | Enable or disable AUTO TEAR OFF function. The feed delay for the tear-off advance can be set.   |
| LOADING        | This determines the action of the printer while the single sheet paper is front feeding.<br>PUSH KEY disables automatic loading allowing loading only by pressing the LF/FF key. The other options allow automatic feeding after the stated delay time. |
| SKEW DETECTION | Enable or Disable the skew detection for front feeding.   |
| SKEW LEVEL     | Sets the Skew sensor sensitivity. 001 is the most critical while 010 is the least. If a skew error is detected the single sheet will be automatically ejected. Note: With setting "1" manual feed becomes highly difficult.                             |

Table 5-2 Description of Options

## Restoring Factory Printer Settings

You can restore to the factory printer settings without having to work through the Setup Menu System to reset the menus.

To restore to the factory settings:

1. Make sure that the printer is **ONLINE**
2. Press and hold down the **ONLINE** and **COPY** keys on the control panel for 3 seconds.

The LED's of the **POWER** and **ONLINE** on the control panel flash 3 times respectively at the same time and the printer makes a beep to confirm that the printer's factory settings have been restored.

3. Release the keys and switch the printer off and on again.

*After these steps, the printer's factory settings work.*

## Using the Self Test Functions

### Slide Pattern Printing Test

One page printing of ASCII slide pattern is performed by turning power on, while pressing the **LF/FF** key.

Continuous printing of ASCII slide pattern is performed by turning power on, while pressing the **ON- LINE** and **PARK/LOAD** keys.

```
          ASCII TEST MODE
Version: 390V X.X 20XX/XX/XX
!"#$%&'()*+,-./10123456789:;<=>?@ABCDEFGHIJKLMN OPQRSTUVWXYZ[\]^_`abcdefghijklmnop
!"#$%&'()*+,-./10123456789:;<=>?@ABCDEFGHIJKLMN OPQRSTUVWXYZ[\]^_`abcdefghijklmnop
!"#$%&'()*+,-./10123456789:;<=>?@ABCDEFGHIJKLMN OPQRSTUVWXYZ[\]^_`abcdefghijklmnop
```

Figure 5-4 The former of English self-test

### Maintenance Printing Test (H pattern)

One page printing of H pattern is performed by turning power on, while pressing the **ONLINE** and **LF/FF** keys.

Continuous printing of H pattern is performed by turning power on, while pressing the **COPY** key.

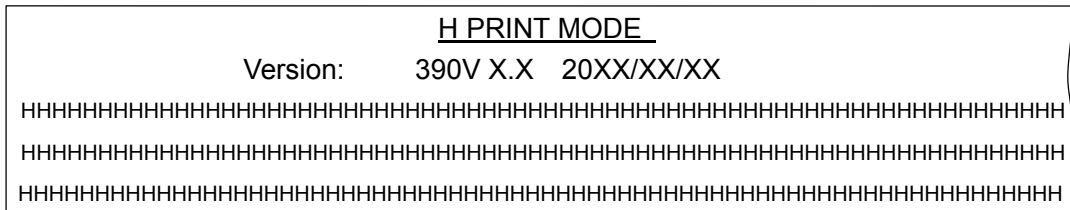

Figure 5-5 The former of the maintenance print

## Hex Dump Mode

Turning power on while pressing the **PARK/LOAD** key causes the printer to enter Hex Dump mode. In this mode, if you execute the following program

```

10 LPRINT CHR$(27); "4";
20 LPRINT "ABCDEFGHIJKLMNPOQRSTUVWXYZ"
30 LPRINT CHR$(27); "5";
40 LPRINT "ABCDEFGHIJKLMNPOQRSTUVWXYZ"

```

The results of the hex dump printing will be shown as follows.

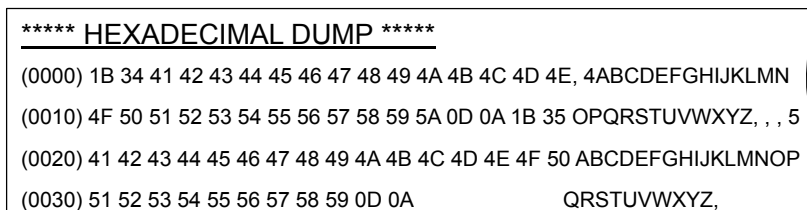

Figure 5-6 The hexadecimal dump printing

# Appendix A

## Maintenance and Fault Finding

### Introduction

Your printer requires very little routine maintenance. In fact, the best maintenance for the printer is preventative. If you have followed the suggestions for locating it in an area free of excessive dust and heat it will give you a long and trouble-free performance.

Periodic cleaning, replacement of the ribbon, replacement of an occasional blown fuse and, after a very long time, replacement of the print head are about the only maintenance tasks you'll need to carry out. We'll cover these items in this chapter. However, before carrying out any of these tasks make sure that the printer has been switched off.

Cleaning dirt and dust are the biggest enemies. The print head cover will keep most dirt from the printer mechanism, but occasional cleaning to remove paper particles is a good idea.

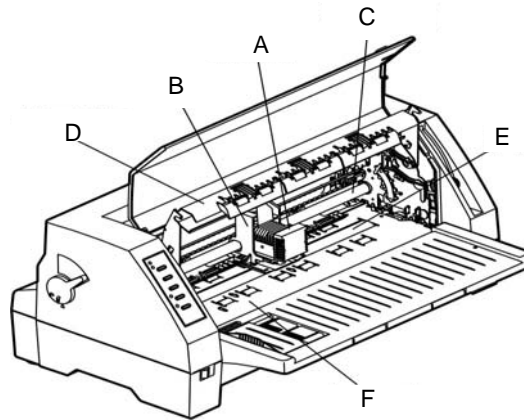

- |   |                |   |                      |
|---|----------------|---|----------------------|
| A | Print head     | D | Sub friction roller  |
| B | Carriage       | E | Platen               |
| C | Carriage shaft | F | Paper guide platform |

**Figure A-1**

### Cleaning the Cabinet

---

Wipe soiled parts of the printer with a clean dry cloth. Remove bits of paper, etc., using tweezers.

#### **NOTE**

**When cleaning, be careful not to scratch the equipment or to bend parts, etc.**

### Cleaning the Carriage Shaft

---

The carriage shaft is coated with oil, which attracts dust, etc. wipe solid parts with a soft cloth to clean them.

**NOTE**

**Over-application of oil may cause a build up of dust and dirt with resulting printer failure.**

**Cleaning the platen**

---

Clean the platen with a soft cloth.

**Intervals and Materials for Cleaning**

---

Clean inside the printer in accordance with the following:

**NOTE**

**Intervals cleaning:      Every 6 months or 300 hours of operation.  
   (Whichever comes first)**

**Materials:                      Dry cloth (gauze or soft cloth)**

**Ribbon Cartridge** The inked ribbon in the cartridge is a continuous loop and will print several million characters before needing replacement. When printed characters begin to appear faint, it is time to replace ribbon cartridge.

Replacing the ribbon is a simple matter of taking out the old cartridge and replacing it with a new one. Before removing the old cartridge always turn off the power and allow the print head to cool, as it can be extremely hot. Then slide the print head to the left edge to avoid damage to the print head cable. See the ribbon installation section in Chapter 2 for details.

**Problems And Solutions**

The following are some of the common problems, which you may encounter when using the printer. By implementing the solutions suggested, you should be able to resolve them.

**Printer is “Dead” No Light, No Action** Make sure that it is plugged in, check both ends of the power cable. Make sure the power switch is turned on. Test the socket with another appliance to make sure it is working, check the fuse in the plug attached to the power cable. Take your printer to your dealer to be serviced.

**Printer Won’t Work** Be sure that the printer cable is plugged into both the printer and the computer. Make sure that there is paper inserted and the **ONLINE LED** is on.

**Printing is Feint** Be sure that the ribbon cartridge is installed correctly. It must be fitted securely into place and the ribbon must pass between the print head and the ribbon mark. Adjust the gap adjust lever (move it upward). Replace the ribbon. Replace the print head.

**Printing is Smudged** The ribbon is in front of the ribbon mask. Remove it and then insert it correctly. Adjust the gap adjust lever (move it downward).

**Poor Dot Positioning** If poor dot positioning occurs, the horizontal dot alignment has to be performed by an authorized technician.

**Characters On The Screen Don't Match The Printed Characters** Many graphics characters and special symbols are produced by different ASCII codes on each make of computer and printer. Compare the character set charts in your computer manual with the printer character sets.

**You Selected A Printer Driver In Your Application Program But The Codes Don't Do The Right Thing (Or Anything) On The Printer** Contact your software manufacture to check if a driver for your printer is available.

**The Paper Jams Frequently When Using Continuous Forms** Make sure that the incoming and outgoing paper is straight. Be sure that the incoming paper is not sticking.

**The Paper Jams When Doing Reverse Paper Feeds** Be sure that the lid is shut correctly. Don't tear off continuous forms while you are printing. With wider paper the right edge of the first page may not be flat against the platen. Increase the top margin or advance to the second sheet before you start printing.

## Error LED on the Control Panel

In case of printer error, the printer enters offline state and indicates an alarm by blinking the LEDs as shown below.

| LED  | Error                    | Cause   | Remedy  |
|--|--------------------------|---|---|
| The POWER LED blinks and the ONLINE LED is off.            | Paper empty or paper jam | The printer is out of paper or jamming              | Load paper or remove the jammed paper   |
| The POWER and the ONLINE LED blink simultaneously quickly. | Paper slant              | The inserted cut sheet paper is slanting            | Re-insert the cut sheet paper correctly   |
| The POWER and the ONLINE LED blink alternately quickly.    | Home position error      | The print head carrier mechanism is out of position | Turn off the power and turn it on again. If an error still occurs, clean and lubricate the carriage shaft |
| The POWER and the ONLINE LED blink alternately slowly.     | Select lever error       | The select lever is changed after loading paper     | Return the select lever to the correct position   |
| The POWER LED is on and the ONLINE LED blinks.             | Head overheating         | The print head is overheated                        | Automatically cleared when print head temperature decreases   |



# Appendix B

## Specifications

### General

|   |   |                                   |
|---|---|-----------------------------------|
| Type                                      | 24-Pin Flatbed Dot Matrix Impact Printer  |                                   |
| Fonts                                     | 1 DP (Draft)<br>7 LQ (ROMAN, SANSERIF, COURIER, PRESTIGE, SCRIPT, OCRA, OCRB)   |                                   |
| Emulation                                 | Epson ESC/P2  |                                   |
| Memory                                    | 256K bytes (*Input buffer: 132K bytes)  |                                   |
| Interface                                 | Parallel Interface: Centronics (IEEE 1284 NIBBLE mode Compatible)<br>USB Interface: USB 2.0 Full-Speed                                      |                                   |
| Ribbon                                    | Color   | Black                             |
|   | Life  | 4 million characters (draft mode) |
| Power requirements                        | Rated voltage AC 220 V<br>Input voltage range AC 198 to 264 V<br>Rated frequency range 50 to 60 Hz<br>Input frequency range 49.5 to 60.5 Hz |                                   |
| Environmental conditions                  | Operating temperature   | 5~35°C                            |
|   | Operating humidity  | 10%~80%RH(No condensation)        |
|   | Storage temperature   | -20~55°C                          |
|   | Storage humidity  | 5%~85%RH(No condensation)         |
| MTBF                                      | 5,000 hours, except the print head  |                                   |
| MTTR                                      | Less than 20 minutes  |                                   |
| Weight (unpacked)                         | Approx.7.8 Kg   |                                   |
| Physical dimensions (Without front table) | 470×252×207mm (width/depth/height)  |                                   |

### Print Head

|                          |                          |
|--------------------------|--------------------------|
| Print head wire diameter | 0.2mm                    |
| Wire pitch               | 1/180 inch               |
| Print head life          | 200 million strokes/wire |

## Mechanism

|                     |   |         |         |         |
|---------------------|---|---------|---------|---------|
| Print speed         | MODE  | 10 CPI  | 12 CPI  | 15 CPI  |
|                     | Super High-Speed  | 300CPS  | 340 CPS | 420 CPS |
|                     |   | 80 DPI  | 80 DPI  | 80 DPI  |
|                     | DP  | 250CPS  | 300 CPS | 375 CPS |
|                     |   | 120 DPI | 120 DPI | 120 DPI |
|                     | LQ  | 83 CPS  | 100 CPS | 125CPS  |
| 360 DPI             |   | 360 DPI | 360 DPI |         |
| Paper feed Speed    | Paper slew speed (Continuous feed): 5.0 IPS (inches per second) |         |         |         |
|                     | Line spacing: 1/6-inch or programmable in 1/360-inch increments |         |         |         |
| Number of columns   | 110 columns (10 CPI)  |         |         |         |
| Copy capability     | Normal: Original + 2 copies                                     |         |         |         |
|                     | Copy mode 1: Original + 2~4 copies                              |         |         |         |
|                     | Copy mode 2: Original + 6 copies – 1 pass-printing              |         |         |         |
|                     | Copy mode 3: Original + 6 copies – 2 pass-printing              |         |         |         |
| Head gap adjustment | Manual  |         |         |         |
| Resolution          | 360X360 DPI maximum   |         |         |         |

## Paper

|                      |  |   |
|----------------------|--|---|
| Paper size           | Cut sheet  | Width: 89 to 340 mm<br>Length: 56 to 462 mm |
|                      | Fanfold  | Width: 101 to 325 mm                        |
| Paper thickness      | Cut sheet: 0.06~0.12mm   |   |
|                      | Fanfold paper: 0.06~0.12 mm – Single sheet<br>0.06~0.45 mm – Total                                     |   |
| Paper type           | Cut sheet, tractor paper, label, check, post card, and envelope  |   |
| Paper feed mechanism | Friction: manual insertion from the front table, ejection to the front                                 |   |
|                      | Tractor: insertion from the rear, ejection to the front, with the function of tear-off and paper park. |   |

## Print mode specifications

| Print mode                        |       | Multipart mode | Dot Spacing (V×H inches) | Max No. of Columns | Character Structure (V×H) | Printing Speed (cps) |
|-----------------------------------|-------|----------------|--------------------------|--------------------|---------------------------|----------------------|
| LQ<br>(Normal Speed)              | 10dpi | Normal         | 1/180×1/360              | 110                | 24×18                     | 83                   |
|                                   |       | Dark 1         |                          |                    |                           | 66                   |
|                                   |       | Dark 2         |                          |                    |                           | 53                   |
|                                   |       | Dark 3         |                          |                    |                           | 26                   |
|                                   | 12dpi | Normal         | 1/180×1/360              | 132                | 24×18                     | 100                  |
|                                   |       | Dark 1         |                          |                    |                           | 80                   |
|                                   |       | Dark 2         |                          |                    |                           | 64                   |
|                                   |       | Dark 3         |                          |                    |                           | 32                   |
|                                   | 15dpi | Normal         | 1/180×1/360              | 165                | 16×12                     | 125                  |
|                                   |       | Dark 1         |                          |                    |                           | 100                  |
|                                   |       | Dark 2         |                          |                    |                           | 80                   |
|                                   |       | Dark 3         |                          |                    |                           | 40                   |
| Draft<br>(High Speed)             | 10dpi | Normal         | 1/180×1/120              | 110                | 24×9                      | 250                  |
|                                   |       | Dark 1         |                          |                    |                           | 200                  |
|                                   |       | Dark 2         |                          |                    |                           | 160                  |
|                                   |       | Dark 3         |                          |                    |                           | 80                   |
|                                   | 12dpi | Normal         | 1/180×1/120              | 132                | 24×7                      | 300                  |
|                                   |       | Dark 1         |                          |                    |                           | 240                  |
|                                   |       | Dark 2         |                          |                    |                           | 192                  |
|                                   |       | Dark 3         |                          |                    |                           | 89                   |
|                                   | 15dpi | Normal         | 1/180×1/120              | 165                | 16×7                      | 375                  |
|                                   |       | Dark 1         |                          |                    |                           | 300                  |
|                                   |       | Dark 2         |                          |                    |                           | 240                  |
|                                   |       | Dark 3         |                          |                    |                           | 120                  |
| Speed-Draft<br>(Super-High Speed) | 10dpi | Normal         | 1/180×1/80               | 110                | 24×6                      | 300                  |
|                                   |       | Dark 1         |                          |                    |                           | 240                  |
|                                   |       | Dark 2         |                          |                    |                           | 192                  |
|                                   |       | Dark 3         |                          |                    |                           | 96                   |
|                                   | 12dpi | Normal         | 1/180×1/80               | 132                | 24×5                      | 340                  |
|                                   |       | Dark 1         |                          |                    |                           | 272                  |
|                                   |       | Dark 2         |                          |                    |                           | 217                  |
|                                   |       | Dark 3         |                          |                    |                           | 108                  |
|                                   | 15dpi | Normal         | 1/180×1/80               | 165                | 16×4                      | 420                  |
|                                   |       | Dark 1         |                          |                    |                           | 336                  |
|                                   |       | Dark 2         |                          |                    |                           | 268                  |
|                                   |       | Dark 3         |                          |                    |                           | 134                  |

## Graphic Print Specifications

| Graphic type |      | Horizontal dot pitch | Multipart mode | Print speed (inch/second) |
|--------------|------|----------------------|----------------|---------------------------|
| Density      | Pins |                      |                |                           |
| 120dpi       | 24   | 1/240 inch           | Normal、Dark 1  | 9.9                       |
|              |      |                      | Dark 2         | 8                         |
|              |      |                      | Dark 3         | 3.9                       |
| 180dpi       | 24   | 1/360 inch           | Normal、Dark 1  | 6.6                       |
|              |      |                      | Dark 2         | 5.3                       |
|              |      |                      | Dark 3         | 2.6                       |
| 360dpi       | 24   | 1/360 inch           | Normal、Dark 1  | 6.6                       |
|              |      |                      | Dark 2         | 5.3                       |
|              |      |                      | Dark 3         | 2.6                       |

## Parallel Interface

Signal level

Input High level: 2 to 5V, Low level: 0 to 0.8V

Output High level: 2.4 to 5V, Low level: 0 to 0.4V

### Connector Pin Assignments

| Signal Pin No. | Return Line Pin No. | Signal Name  | Signal Direction |
|----------------|---------------------|--------------|------------------|
| 1              | 19                  | /STROBE      | Printer ← Host   |
| 2~9            | 20~27               | DATA         | Printer ← Host   |
| 10             | 28                  | /ACK         | Printer → Host   |
| 11             | 29                  | BUSY         | Printer → Host   |
| 12             | 30                  | PE           | Printer → Host   |
| 13             | —                   | SELECT       | Printer → Host   |
| 14             | —                   | /AUTO FEED   | Printer ← Host   |
| 15             | —                   | NC           | NC               |
| 16             | —                   | SIGNAL GND   | Printer ↔ Host   |
| 17             | —                   | CHASSIS GND  | Printer ↔ Host   |
| 18             | —                   | +5V          | Printer → Host   |
| 31             | —                   | /PRIME       | Printer ← Host   |
| 32             | —                   | /ERROR       | Printer → Host   |
| 33             | —                   | SIGNAL GND   | Printer ↔ Host   |
| 34             | —                   | NC           | Printer → Host   |
| 35             | —                   | PULLED UP 5V | Printer → Host   |
| 36             | —                   | /SELECT IN   | Printer ← Host   |

## USB Interface

USB 2.0 Full-Speed.

The following table provides the standardized contact terminating assignments by number and electrical value for Series “A” and Series “B” connectors.

| Contact Number | Signal Name | Typical Wiring Assignment |
|----------------|-------------|---------------------------|
| 1              | VBUS        | Red                       |
| 2              | D-          | White                     |
| 3              | D+          | Green                     |
| 4              | GND         | Black                     |
| Shell          | Shield      | Wire                      |

## Command Code Summary

### Epson Emulation

| Name                                 | Code<br>(Symbol) | Code<br>(Hex.)                                  | Code<br>(Dec.)                                  |
|--------------------------------------|------------------|---|---|
| <b>Print and Line Feed Execution</b> |                  |   |   |
| Carriage Return                      | CR               | 0D <sub>h</sub>                                 | 13 <sub>d</sub>                                 |
| Line Feed                            | LF               | 0A <sub>h</sub>                                 | 10 <sub>d</sub>                                 |
| n/180” Line Feed                     | ESC J            | 1B <sub>h</sub> 4A <sub>h</sub>                 | 27 <sub>d</sub> 74 <sub>d</sub>                 |
| n/180” Reverse Line Feed             | ESC j            | 1B <sub>h</sub> 6A <sub>h</sub>                 | 27 <sub>d</sub> 106 <sub>d</sub>                |
| <b>Format Control</b>                |                  |   |   |
| Set 1/8” Line Spacing                | ESC 0            | 1B <sub>h</sub> 30 <sub>h</sub>                 | 27 <sub>d</sub> 48 <sub>d</sub>                 |
| Set 1/6” Line Spacing                | ESC 2            | 1B <sub>h</sub> 32 <sub>h</sub>                 | 27 <sub>d</sub> 50 <sub>d</sub>                 |
| Set n/180” Line Spacing              | ESC 3            | 1B <sub>h</sub> 32 <sub>h</sub>                 | 27 <sub>d</sub> 51 <sub>d</sub>                 |
| Set n/60” Line Spacing               | ESC A            | 1B <sub>h</sub> 41 <sub>h</sub>                 | 27 <sub>d</sub> 65 <sub>d</sub>                 |
| Set n/360” Line Spacing              | ESC +            | 1B <sub>h</sub> 2B <sub>h</sub>                 | 27 <sub>d</sub> 43 <sub>d</sub>                 |
| Form Feed                            | FF               | 0C <sub>h</sub>                                 | 12 <sub>d</sub>                                 |
| Set Form Length in Lines             | ESC C            | 1B <sub>h</sub> 43 <sub>h</sub>                 | 27 <sub>d</sub> 67 <sub>d</sub>                 |
| Set Form Length in Inches            | ESC C NUL        | 1B <sub>h</sub> 43 <sub>h</sub> 00 <sub>h</sub> | 27 <sub>d</sub> 67 <sub>d</sub> 0 <sub>d</sub>  |
| Set Form Length in Defined Unit      | ESC ( C          | 1B <sub>h</sub> 28 <sub>h</sub> 43 <sub>h</sub> | 27 <sub>d</sub> 40 <sub>d</sub> 67 <sub>d</sub> |
| Select Skip-Over-Perforation         | ESC N n          | 1B <sub>h</sub> 4E <sub>h</sub>                 | 27 <sub>d</sub> 78 <sub>d</sub>                 |
| Cancel Skip-Over-Perforation         | ESC O            | 1B <sub>h</sub> 4F <sub>h</sub>                 | 27 <sub>d</sub> 79 <sub>d</sub>                 |
| Vertical Tab                         | VT               | 0B <sub>h</sub>                                 | 11 <sub>d</sub>                                 |
| Set Vertical Tab Positions           | ESC B            | 1B <sub>h</sub> 42 <sub>h</sub>                 | 27 <sub>d</sub> 66 <sub>d</sub>                 |
| Select a VFU Channel                 | ESC /            | 1B <sub>h</sub> 2F <sub>h</sub>                 | 27 <sub>d</sub> 47 <sub>d</sub>                 |
| Select VFU Positions                 | ESC b            | 1B <sub>h</sub> 62 <sub>h</sub>                 | 27 <sub>d</sub> 98 <sub>d</sub>                 |
| Set right Margin                     | ESC Q            | 1B <sub>h</sub> 51 <sub>h</sub>                 | 27 <sub>d</sub> 81 <sub>d</sub>                 |
| Set Left Margin                      | ESC I            | 1B <sub>h</sub> 6C <sub>h</sub>                 | 27 <sub>d</sub> 108 <sub>d</sub>                |

| Name                                 | Code<br>(Symbol) | Code<br>(Hex.)                                  | Code<br>(Dec.)                                   |
|--------------------------------------|------------------|---|--|
| Horizontal Tab                       | HT               | 09 <sub>h</sub>                                 | 9 <sub>d</sub>                                   |
| Set Horizontal Tab Positions         | ESC D            | 1B <sub>h</sub> 44 <sub>h</sub>                 | 27 <sub>d</sub> 68 <sub>d</sub>                  |
| Set Character Space                  | ESC SP           | 1B <sub>h</sub> 20 <sub>h</sub>                 | 27 <sub>d</sub> 32 <sub>d</sub>                  |
| Set Absolute Horizontal Tab          | ESC \$           | 1B <sub>h</sub> 24 <sub>h</sub>                 | 27 <sub>d</sub> 36 <sub>d</sub>                  |
| Set Relative Dot Position            | ESC \            | 1B <sub>h</sub> 5C <sub>h</sub>                 | 27 <sub>d</sub> 92 <sub>d</sub>                  |
| Define Unit                          | ESC ( U          | 1B <sub>h</sub> 28 <sub>h</sub> 55 <sub>h</sub> | 27 <sub>d</sub> 40 <sub>d</sub> 85 <sub>d</sub>  |
| Set Absolute Vertical Print Position | ESC ( V          | 1B <sub>h</sub> 28 <sub>h</sub> 56 <sub>h</sub> | 27 <sub>d</sub> 40 <sub>d</sub> 86 <sub>d</sub>  |
| Set Relative Vertical Print Position | ESC ( v          | 1B <sub>h</sub> 28 <sub>h</sub> 76 <sub>h</sub> | 27 <sub>d</sub> 40 <sub>d</sub> 118 <sub>d</sub> |
| Set Form Format                      | ESC ( c          | 1B <sub>h</sub> 28 <sub>h</sub> 63 <sub>h</sub> | 27 <sub>d</sub> 40 <sub>d</sub> 99 <sub>d</sub>  |
| Set Horizontal Motion Index (HM)     | ESC c            | 1B <sub>h</sub> 63 <sub>h</sub>                 | 27 <sub>d</sub> 99 <sub>d</sub>                  |
| <b>Print Mode</b>                    |                  |   |  |
| Select Print Quality                 | ESC x            | 1B <sub>h</sub> 78 <sub>h</sub>                 | 27 <sub>d</sub> 120 <sub>d</sub>                 |
| Select ELITE Width Mode (12CPI)      | ESC M            | 1B <sub>h</sub> 4D <sub>h</sub>                 | 27 <sub>d</sub> 77 <sub>d</sub>                  |
| Select PICA Width Mode (10CPI)       | ESC P            | 1B <sub>h</sub> 50 <sub>h</sub>                 | 27 <sub>d</sub> 80 <sub>d</sub>                  |
| Select 15CPI Mode                    | ESC g            | 1B <sub>h</sub> 67 <sub>h</sub>                 | 27 <sub>d</sub> 103 <sub>d</sub>                 |
| Select/Cancel Proportional Mode      | ESC p            | 1B <sub>h</sub> 70 <sub>h</sub>                 | 27 <sub>d</sub> 112 <sub>d</sub>                 |
| Select Double Width Mode (one line)  | SO               | 0E <sub>h</sub>                                 | 14 <sub>d</sub>                                  |
| Cancel Double Width Mode (one line)  | DC4              | 14 <sub>h</sub>                                 | 20 <sub>d</sub>                                  |
| Select/Cancel Double Width Mode      | ESC W            | 1B <sub>h</sub> 57 <sub>h</sub>                 | 27 <sub>d</sub> 87 <sub>d</sub>                  |
| Select Compressed Mode               | SI               | 0F <sub>h</sub>                                 | 15 <sub>d</sub>                                  |
| Cancel Compressed Mode               | DC2              | 12 <sub>h</sub>                                 | 18 <sub>d</sub>                                  |
| Select Emphasized Mode               | ESC E            | 1B <sub>h</sub> 45 <sub>h</sub>                 | 27 <sub>d</sub> 69 <sub>d</sub>                  |
| Cancel Emphasized Mode               | ESC F            | 1B <sub>h</sub> 46 <sub>h</sub>                 | 27 <sub>d</sub> 70 <sub>d</sub>                  |
| Select Double Strike Mode            | ESC G            | 1B <sub>h</sub> 47 <sub>h</sub>                 | 27 <sub>d</sub> 71 <sub>d</sub>                  |
| Cancel Double Strike Mode            | ESC H            | 1B <sub>h</sub> 48 <sub>h</sub>                 | 27 <sub>d</sub> 72 <sub>d</sub>                  |
| Select Italic Mode                   | ESC 4            | 1B <sub>h</sub> 34 <sub>h</sub>                 | 27 <sub>d</sub> 52 <sub>d</sub>                  |
| Cancel Italic Mode                   | ESC 5            | 1B <sub>h</sub> 35 <sub>h</sub>                 | 27 <sub>d</sub> 53 <sub>d</sub>                  |
| Select/Cancel Underline Mode         | ESC - n          | 1B <sub>h</sub> 2D <sub>h</sub>                 | 27 <sub>d</sub> 45 <sub>d</sub>                  |
| Select Superscript/Subscript Mode    | ESC S n          | 1B <sub>h</sub> 53 <sub>h</sub>                 | 27 <sub>d</sub> 83 <sub>d</sub>                  |
| Cancel Superscript/Subscript Mode    | ESC T            | 1B <sub>h</sub> 54 <sub>h</sub>                 | 27 <sub>d</sub> 84 <sub>d</sub>                  |
| Select Print Mode                    | ESC ! n          | 1B <sub>h</sub> 21 <sub>h</sub>                 | 27 <sub>d</sub> 33 <sub>d</sub>                  |
| Select/Cancel Double Height Mode     | ESC w n          | 1B <sub>h</sub> 77 <sub>h</sub>                 | 27 <sub>d</sub> 119 <sub>d</sub>                 |
| Select/Cancel Quiet Print Mode       | ESC s n          | 1B <sub>h</sub> 73 <sub>h</sub>                 | 27 <sub>d</sub> 115 <sub>d</sub>                 |
| Select Justification Mode            | ESC a n          | 1B <sub>h</sub> 61 <sub>h</sub>                 | 27 <sub>d</sub> 97 <sub>d</sub>                  |
| Select Character Style               | ESC q n          | 1B <sub>h</sub> 71 <sub>h</sub>                 | 27 <sub>d</sub> 113 <sub>d</sub>                 |
| Define and Apply a Style of Scoring  | ESC ( -          | 1B <sub>h</sub> 28 <sub>h</sub> 2D <sub>h</sub> | 27 <sub>d</sub> 40 <sub>d</sub> 45 <sub>d</sub>  |
| Print Data as Characters             | ESC ( ^          | 1B <sub>h</sub> 28 <sub>h</sub> 5E <sub>h</sub> | 27 <sub>d</sub> 40 <sub>d</sub> 94 <sub>d</sub>  |
| <b>Character Set</b>                 |                  |   |  |
| Select International Character Set   | ESC R            | 1B <sub>h</sub> 52 <sub>h</sub>                 | 27 <sub>d</sub> 82 <sub>d</sub>                  |
| Select Font Style                    | ESC k            | 1B <sub>h</sub> 6B <sub>h</sub>                 | 27 <sub>d</sub> 107 <sub>d</sub>                 |
| Select Character Table               | ESC t n          | 1B <sub>h</sub> 74 <sub>h</sub>                 | 27 <sub>d</sub> 116 <sub>d</sub>                 |

| Name                                | Code<br>(Symbol) | Code<br>(Hex.)                                  | Code<br>(Dec.)                                   |
|-------------------------------------|------------------|---|--|
| Enable Character Set 2              | ESC 6            | 1B <sub>h</sub> 36 <sub>h</sub>                 | 27 <sub>d</sub> 54 <sub>d</sub>                  |
| Cancel command ESC 6                | ESC 7            | 1B <sub>h</sub> 37 <sub>h</sub>                 | 27 <sub>d</sub> 55 <sub>d</sub>                  |
| Assign Character Table              | ESC ( t          | 1B <sub>h</sub> 28 <sub>h</sub> 74 <sub>h</sub> | 27 <sub>d</sub> 40 <sub>d</sub> 116 <sub>d</sub> |
| <b>Download Character</b>           |                  |   |  |
| Select/Deselect User-Defined Set    | ESC % n          | 1B <sub>h</sub> 25 <sub>h</sub>                 | 27 <sub>d</sub> 37 <sub>d</sub>                  |
| Define Downloaded Characters        | ESC &            | 1B <sub>h</sub> 26 <sub>h</sub>                 | 27 <sub>d</sub> 38 <sub>d</sub>                  |
| Copy ROM Characters Set into RAM    | ESC:             | 1B <sub>h</sub> 3A <sub>h</sub>                 | 27 <sub>d</sub> 58 <sub>d</sub>                  |
| <b>Bit-Image</b>                    |                  |   |  |
| Select Single-Density Graphics Mode | ESC K            | 1B <sub>h</sub> 4B <sub>h</sub>                 | 27 <sub>d</sub> 75 <sub>d</sub>                  |
| Select Double-Density Graphics Mode | ESC L            | 1B <sub>h</sub> 4C <sub>h</sub>                 | 27 <sub>d</sub> 76 <sub>d</sub>                  |
| Select High-speed, Double-Density   | ESC Y            | 1B <sub>h</sub> 59 <sub>h</sub>                 | 27 <sub>d</sub> 89 <sub>d</sub>                  |
| Select Quadruple-Density            | ESC Z            | 1B <sub>h</sub> 5A <sub>h</sub>                 | 27 <sub>d</sub> 90 <sub>d</sub>                  |
| <b>Graphics Mode</b>                |                  |   |  |
| Select Graphics Mode                | ESC *            | 1B <sub>h</sub> 2A <sub>h</sub>                 | 27 <sub>d</sub> 42 <sub>d</sub>                  |
| Reassign Graphics Mode              | ESC ?            | 1B <sub>h</sub> 3F <sub>h</sub>                 | 27 <sub>d</sub> 63 <sub>d</sub>                  |
| Select Graphics Mode                | ESC ( G          | 1B <sub>h</sub> 28 <sub>h</sub> 47 <sub>h</sub> | 27 <sub>d</sub> 40 <sub>d</sub> 71 <sub>d</sub>  |
| Print Raster Graphics               | ESC .            | 1B <sub>h</sub> 2E <sub>h</sub>                 | 27 <sub>d</sub> 46 <sub>d</sub>                  |
| <b>Input Data Control</b>           |                  |   |  |
| Cancel Line                         | CAN              | 18 <sub>h</sub>                                 | 24 <sub>d</sub>                                  |
| Delete Character                    | DEL              | 7F <sub>h</sub>                                 | 127 <sub>d</sub>                                 |
| Select Printer                      | DC1              | 11 <sub>h</sub>                                 | 17 <sub>d</sub>                                  |
| Deselect Printer                    | DC3              | 13 <sub>h</sub>                                 | 19 <sub>d</sub>                                  |
| Cancel MSB Control Sequence         | ESC #            | 1B <sub>h</sub> 23 <sub>h</sub>                 | 27 <sub>d</sub> 35 <sub>d</sub>                  |
| Set MSB to 1                        | ESC >            | 1B <sub>h</sub> 3E <sub>h</sub>                 | 27 <sub>d</sub> 62 <sub>d</sub>                  |
| Reset MSB to 0                      | ESC =            | 1B <sub>h</sub> 3D <sub>h</sub>                 | 27 <sub>d</sub> 61 <sub>d</sub>                  |
| <b>Miscellaneous</b>                |                  |   |  |
| Null                                | NUL              | 00 <sub>h</sub>                                 | 0 <sub>d</sub>                                   |
| Beeper                              | BEL              | 07 <sub>h</sub>                                 | 7 <sub>d</sub>                                   |
| Backspace                           | BS               | 08 <sub>h</sub>                                 | 8 <sub>d</sub>                                   |
| Initialize Printer                  | ESC @            | 1B <sub>h</sub> 40 <sub>h</sub>                 | 27 <sub>d</sub> 64 <sub>d</sub>                  |
| Select Unidirectional Mode (online) | ESC <            | 1B <sub>h</sub> 3C <sub>h</sub>                 | 27 <sub>d</sub> 60 <sub>d</sub>                  |
| Select Print Direction              | ESC U n          | 1B <sub>h</sub> 55 <sub>h</sub>                 | 27 <sub>d</sub> 85 <sub>d</sub>                  |

## Select Code Pages

| Format      | ESC ( t n1 n2 d1 d2 d3 (n1=3, n2=0, d1=0, 1, 2, 3) |          |                   |
|-------------|--|----------|-------------------|
| Code No.    | d2   | d3 (HEX) | Name              |
| 437         | 1  | 0        | U.S.A.            |
| 437GR       | 1  | 10       | GRK 437           |
| 858         | 3  | 0        | MULTI             |
| 851GR       | 4  | 0        | GRK 851           |
| 857         | 5  | 0        | TURKEY            |
| 855         | 6  | 0        | CYRILLIC          |
| 860         | 7  | 0        | PORTUGAL          |
| 863         | 8  | 0        | CANADA            |
| 865         | 9  | 0        | NORWAY            |
| 852         | 0A   | 0        | EAST EUROPE       |
| 864         | 0D   | 0        | ARAB NLS          |
| 866         | 0E   | 0        | RUSSIAN           |
| 1253        | 0F   | 0        | GRK 1253          |
| 861         | 18   | 0        | ICELAND           |
| 1252        | 19   | 0        | WIN LAT1          |
| 1250        | 1A   | 0        | WIN LAT2          |
| Hungarian   | 1B   | 0        | HUNGARY           |
| 895         | 1C   | 0        | KAMENICKY         |
| Bulgaria    | 1D   | 0        | BULGARIA          |
| ISO-8859-15 | 1D   | 0F       | ISO LTN9          |
| Mazovia     | 1E   | 0        | MAZOVIA           |
| ISO-8859-7  | 1F   | 0        | GRK 8859-7        |
| ARAB EXT    | 20   | 0        | ARAB EXT          |
| ISO-8859-1  | 21   | 0        | ISO LTN1          |
| ISO-8850-2  | 22   | 0        | ISO LTN2          |
| KBL         | 23   | 0        | KBL               |
| ISO-8859-13 | 24   | 0        | ISO LTN7          |
| ISO-8859-9  | 2C   | 0        | ISO-8859-9 TURKEY |



This printer complies with the regulation about the maximum noise level in the work place – 3. GPSGV, under which the highest noise level has to be 70 dB (A) or less in accordance with ISO7779.

Maschinenlärminformations-Verordnung - 3. GPSGV, der höchste Schalldruckpegel beträgt 70 dB(A) oder weniger gemäß ISO7779.

This unit complies with Low Voltage Directive 2006/95/EC and the EMC Directive 2004/108/EC.

Dies Gerät entspricht den Bedingungen der Niederspannungs-Vorschrift 2006/95/EC und dem EMVG nach 2004/108/EC.

**Company name: SEIKO PRECISION (Europe) GmbH**

**Address: Hermann-Buck-Weg 9, D-22309 Hamburg, Germany**